

C00501GNW1

Part number	C00501GNW1
Number of resistor elements	Dual-unit
Lever direction	SMT
Travel	5mm
Lever type	Optional

Lever length	Optional
Total resistance	500 Ω -1000k Ω
Center detent	Optional
Resistance taper	Optional
Operating temperature range	-25 $^{\circ}$ C--+70 $^{\circ}$ C

Electrical characteristics

Total resistance tolerance	<input type="checkbox"/> $\pm 20\%$ <input type="checkbox"/> Other
Rated power	0.1W
Max. operating voltage	150V AC, 10V DC
Residual resistance	20 Ω max
Sliding noise	less than 100mV
Insulation resistance	100M Ω min., 250V DC
Voltage proof	300V AC for 1 min.

Mechanical characteristics

Operating force	0.3 to 2.5N
Stopper strength	50N
Lever push-pull strength	50N
Lever wobble (2 sides)	1mm
Vibration	10 to 55 to 10Hz/min, amplitude is 1.5mm for all the freque, in X,Y and Z directions and for 2 hours respectively

Durability	Operating life	15.000 cycles
------------	----------------	---------------

MOQ		1000pcs
-----	--	---------

Photo

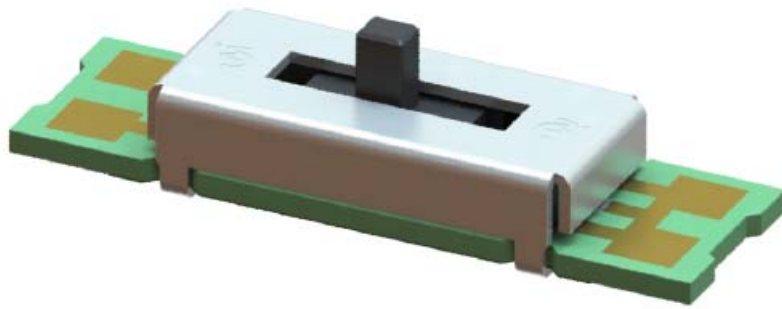

Dimensions

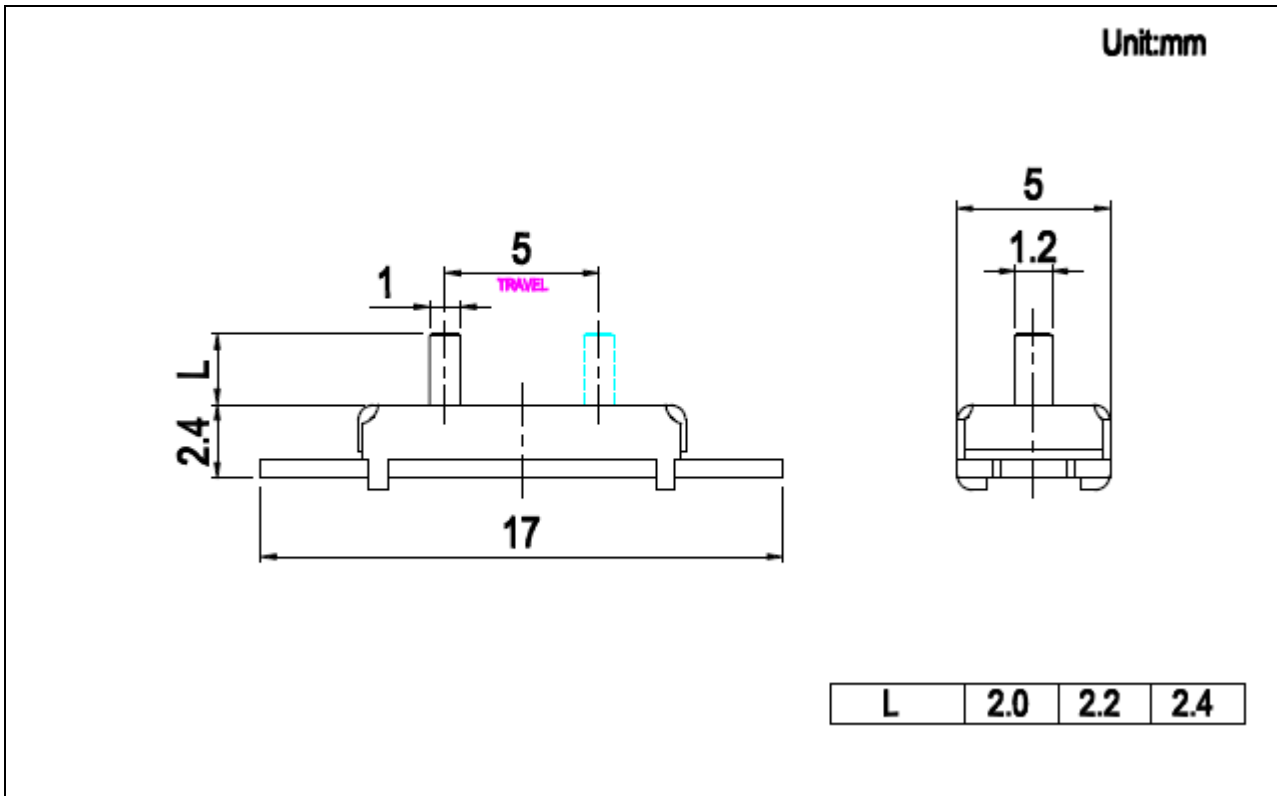

Circuit Diagram

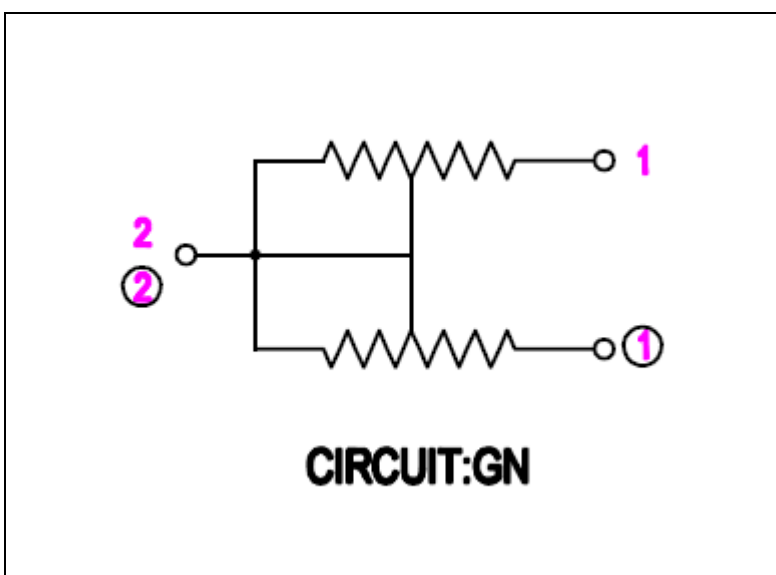

Resistance Taper Options

A Taper	B Taper	C Taper	MN
05 A	1 B	05 C	M
10 A	2 B	10 C	N
15 A	3 B	15 C	
20 A	4 B	20 C	
25 A		25 C	
30 A		30 C	

Packing specifications

Quantity per carton	2000pcs
Packing method	Option
Carton dimension	460X285X310mm

Soldering conditions

Wave soldering

Soldering temperature	260°C ±5°C max.
Soldering time	5 ±1s
No. of solders	1 time max.

Hand soldering

Tip temperature	350°C max.
Soldering time	3s max.
No. of solders	1 time