

E1200XX0H1

Part number	E1200XX0H1
Structure	Vertical
Actuator configuration	Optional
Actuator length	Optional
Number of detent	Optional

Number of pulse	Optional
Push-on switch	Without
Travel of push-on switch	Without
Operating temperature range	-10°C~+70°C

Electrical characteristics

Ratings	0.5mA 5V DC
Output signal	Two phase A and B
Max./min. operating current (Resistive load)	5mA/0.5mA
Insulation resistance	10M Ω min, 50V DC
Voltage proof	50V AC for 1 minute

Mechanical characteristics

Rotational torque	3 to 20mN.m
Push-pull strength	80N

Durability	Operating life	30,000 cycles
MOQ		1,000pcs

Photo

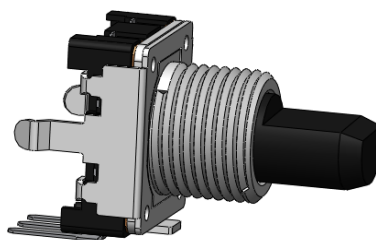

Dimensions

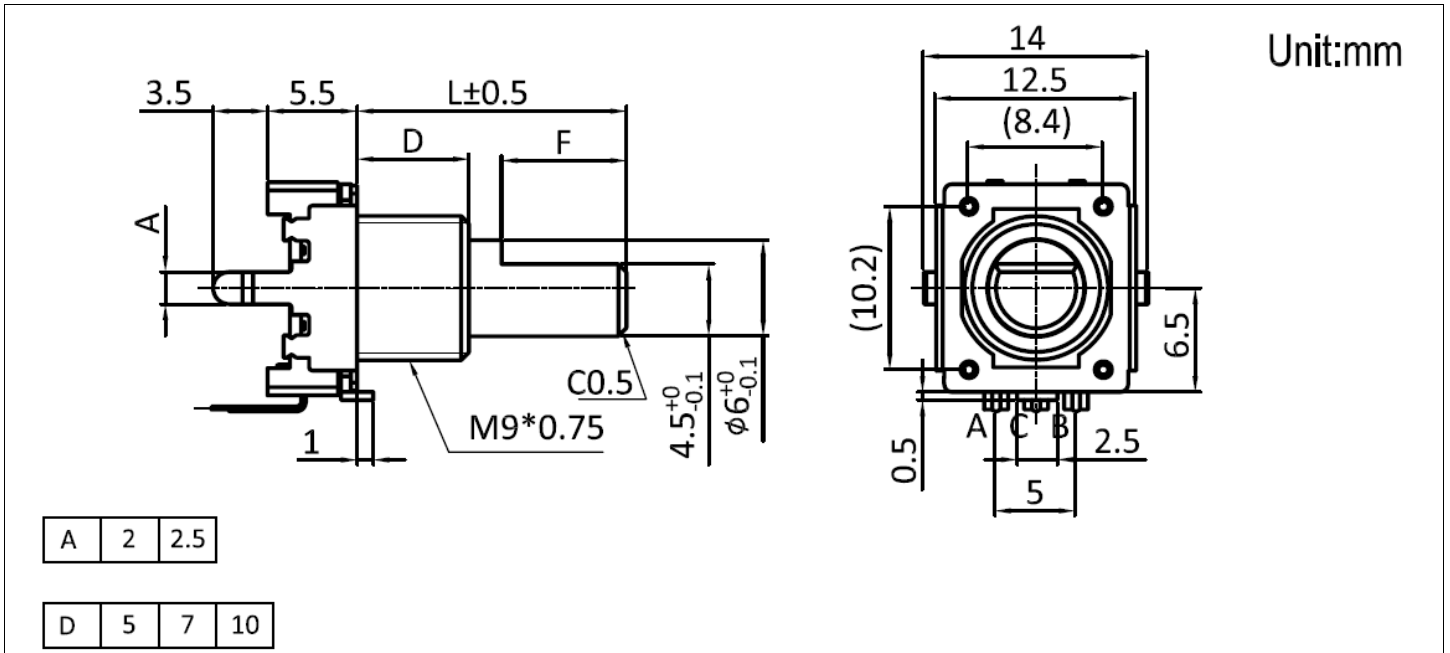

Mounting Hole Dimensions

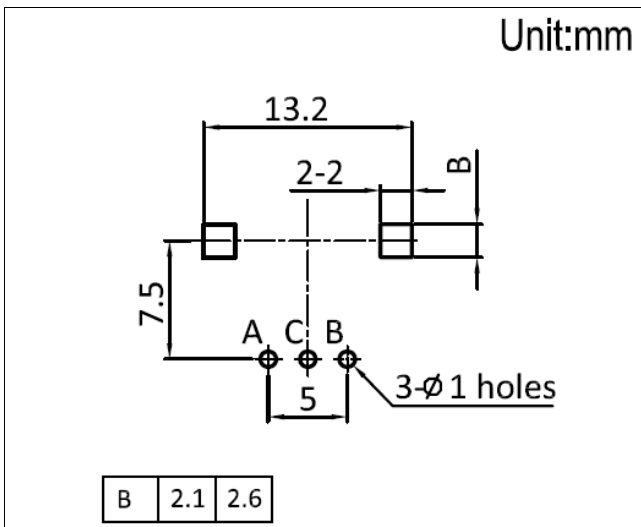

Output Wave

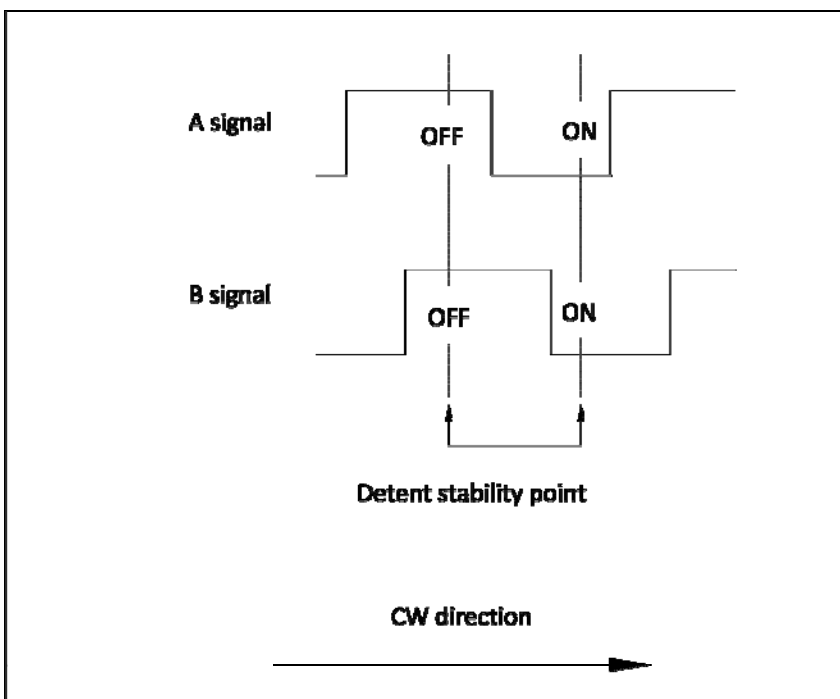

Sliding Noise

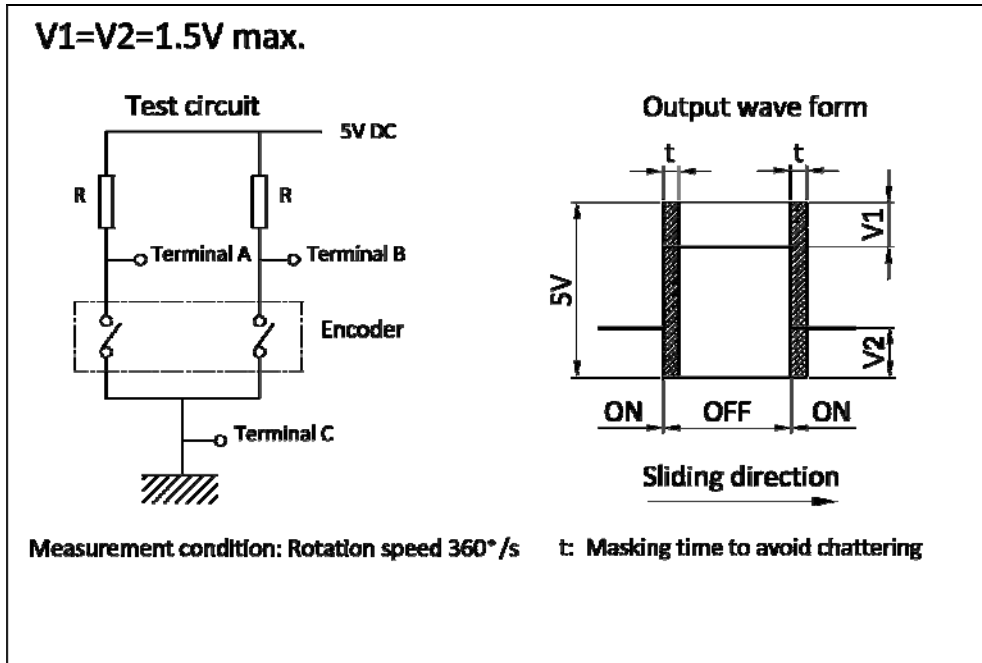

Pulse and Detent Options

Pulse	Detent	Direction
12	12	F
	24	F
24	24	F

Shaft and Shaft Length Options

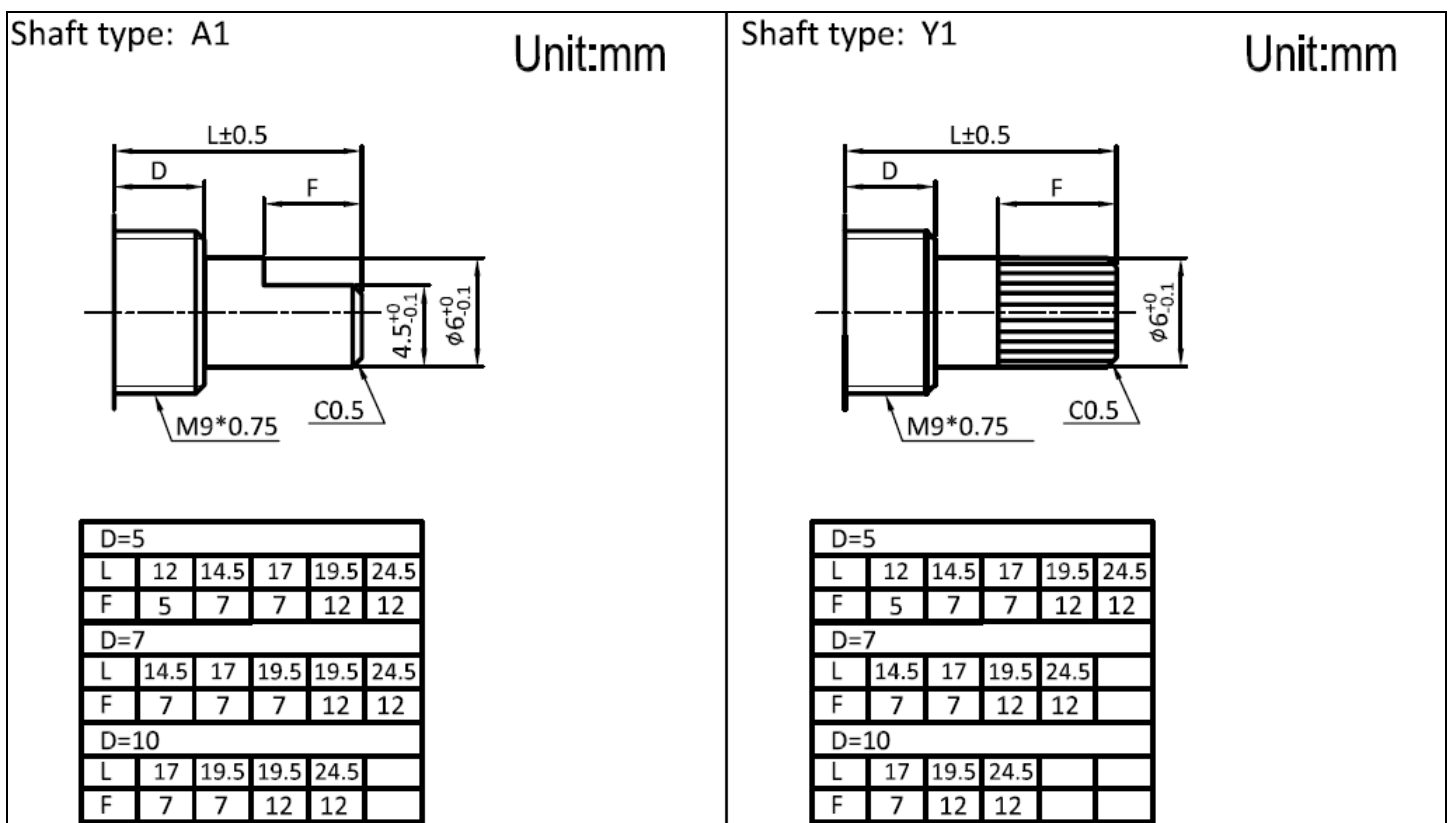

Packing specifications

Quantity per carton	2.000pcs
Packing method	Foam box
Carton dimension	460X285X310mm

Soldering conditions

Wave soldering

Soldering surface temperature	100°C max.
Heating time	2 min. max.
Soldering temperature	260°C ±5°C max.
Soldering time	5 ±1s
No. of solders	2 time max.

Hand soldering

Tip temperature	350°C max.
Soldering time	3s max.
No. of solders	1 time