

E2100AX1H1

Part number	E2100AX1H1
Structure	Vertical
Number of pulses	15
Number of detent	30

Number of pulse	Optional
Push-on switch	Without
Travel of push-on switch	Without
Operating temperature range	-40°C~+85°C

Electrical characteristics

Ratings	10mA 5V DC
Output signal	Two phase A and B
Max./min. operating current (Resistive load)	10mA/1mA
Insulation resistance	100M Ω min, 250V DC
Voltage proof	300V AC for 1 minute

Mechanical characteristics

Rotational torque	4 \pm 2 mN.m
Push-pull strength	100N

Durability	Operating life	50,000 cycles
MOQ		1,000pcs

Photo

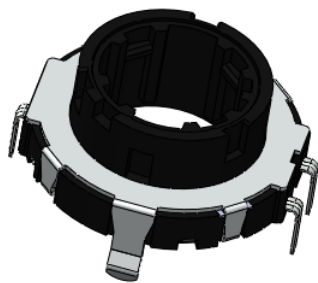

Dimensions

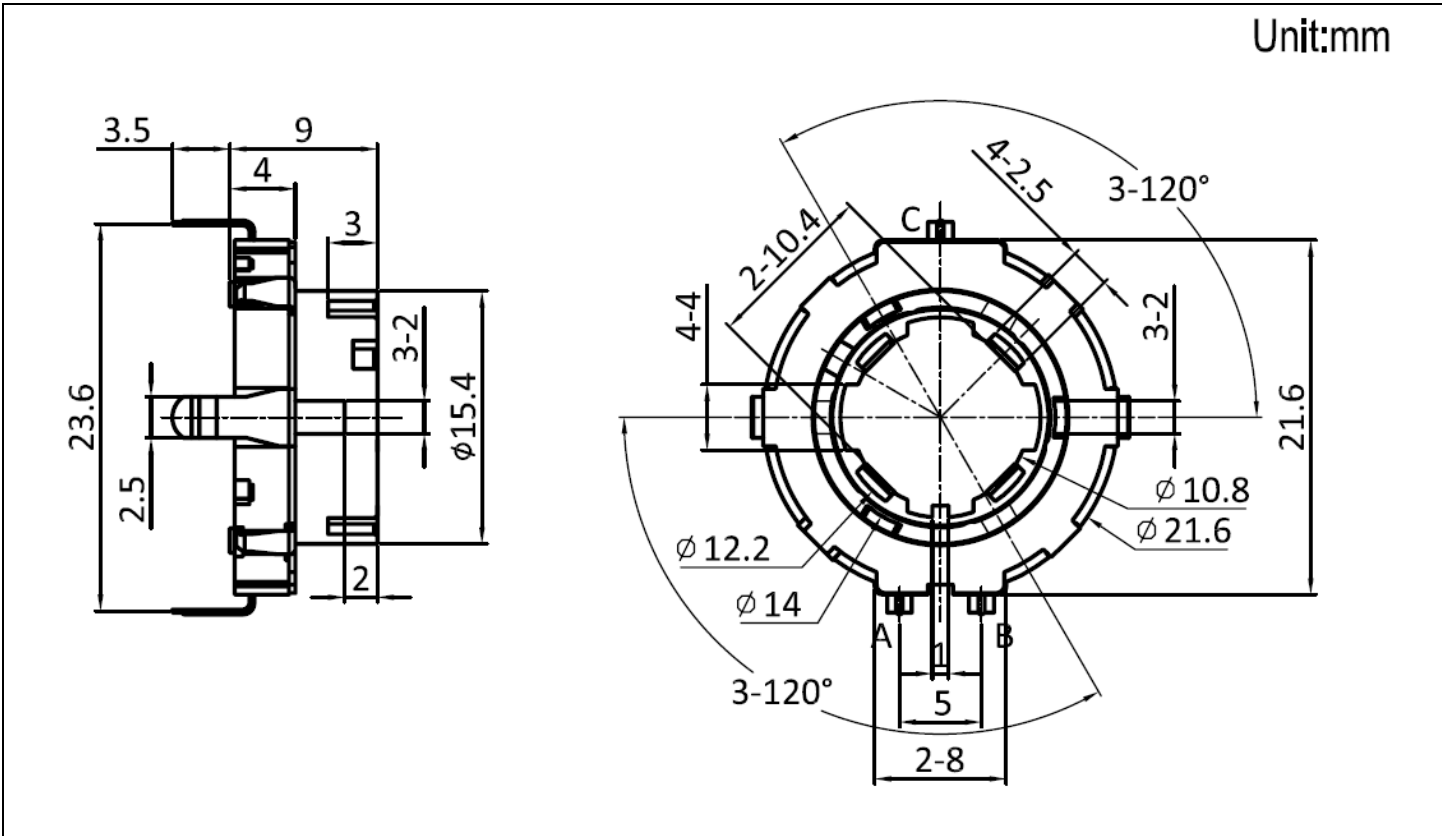

Mounting Hole Dimensions

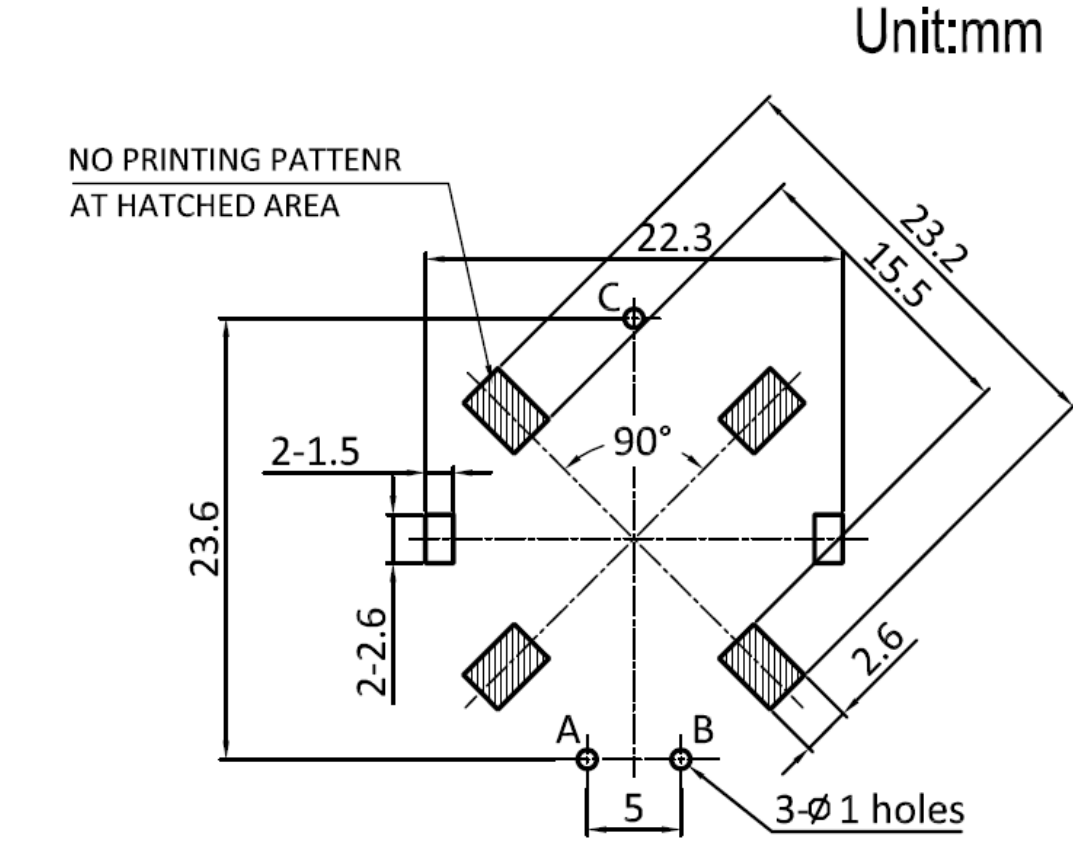

Output Wave

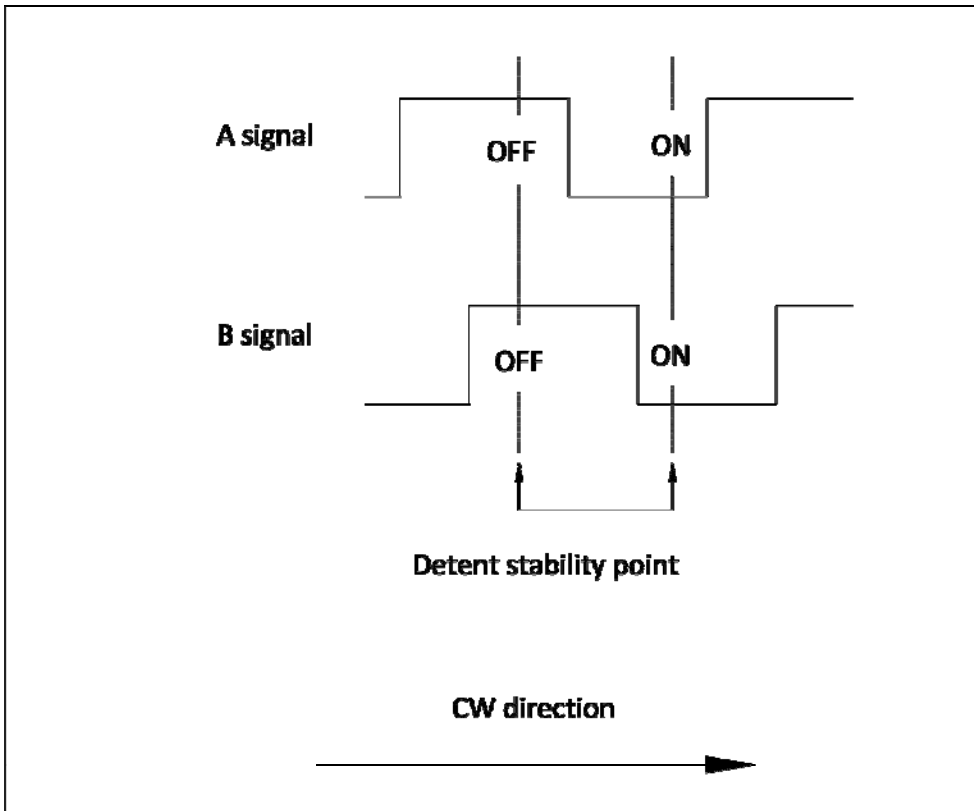

Sliding Noise

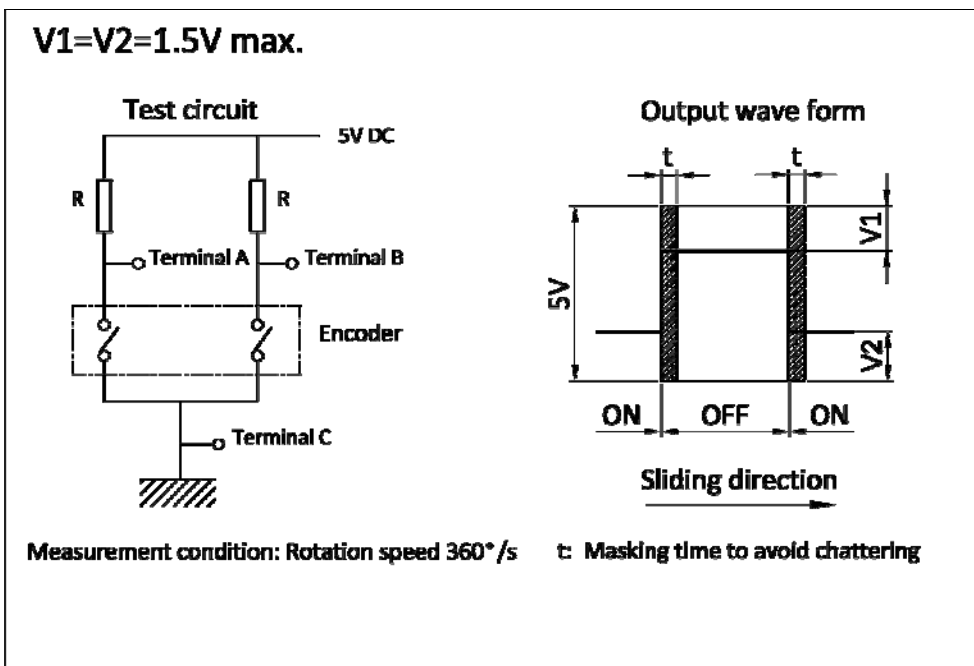

Packing specifications

Quantity per carton	2.000pcs
Packing method	Foam box
Carton dimension	460X285X310mm

Soldering conditions

Wave soldering

Soldering surface temperature	100°C max.
Heating time	2 min. max.
Soldering temperature	260°C \pm 5°C max.
Soldering time	5 \pm 1s
No. of solders	2 time max.

Hand soldering

Tip temperature	350°C max.
Soldering time	3s max.
No. of solders	1 time